

Installation Instructions

⚠ DANGER

**Hazardous voltage.
Will cause severe
injury or death.**

Turn off and lock out all
power before installing or
servicing.

SAFETY INSTRUCTIONS

NOTE: This instruction outlines the recommended installation procedure.

1. Turn off power supplying this device before installing or servicing.
2. Switch must be in off position.
3. Refer to Fig. 1: Mount the auxiliary switch bracket with (2) #8-32 x 1/4 screws and (2) lockwashers to the side opposite of the mechanism as shown.
4. Mount auxiliary actuator onto leg of bail, as shown in Fig. 2.
5. With switch in "off" position, locate auxiliary switch, positioning square tabs in opening of mounting bracket. Be sure actuating finger on auxiliary switch is inserted in ring opening of actuator, then rotate into position. Snap lock at top will secure device.
6. With the power feeding switch still off, use continuity tester to check circuits. With device off, check upper set (N.C.) contacts. Tighten screws, turn device on, and check lower set (N.O.) of contacts. Operate device to insure switch is properly installed.
7. Wiring Instruction: Each auxiliary switch contains one normally open and one normally closed contact that may be wired to separate circuits. Contacts are marked to indicate normally open and normally closed.

CONTACT RATINGS ^①

Volts (AC)	Inrush Amps	Break Amps	Volts (DC)	Inrush Amps	Break Amps
24-120	60	6	24-150	1.1	1.1
240	30	3	250	.55	.55
480	15	1.5	300	.20	.20
600	12	1.2	600	.20	.20

Table 1

- ① Continuous duty: 10 Amps.
Note: All contacts are heavy duty 600V max. A600/P600.

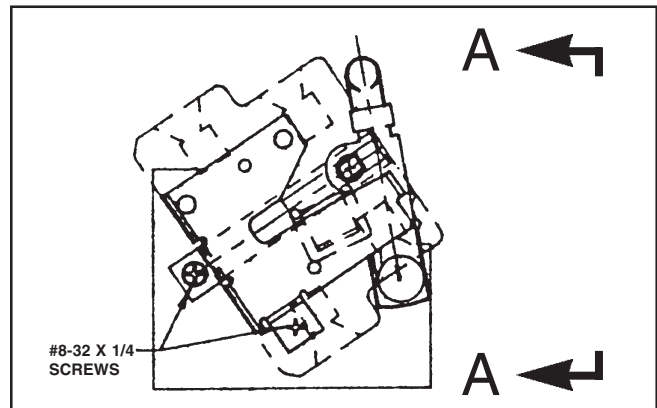

Fig. 1

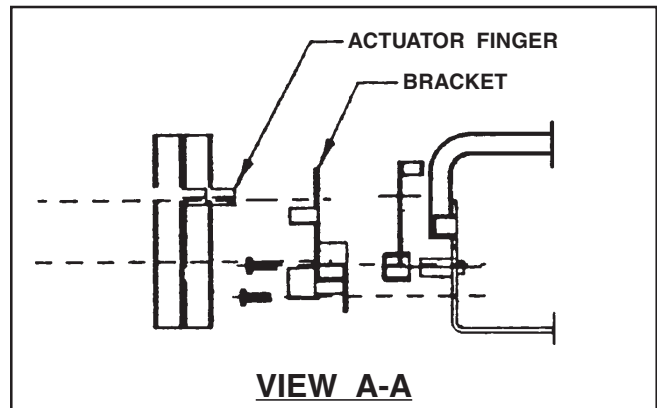

Fig. 2